

CARIBOU STAR

Durbanis
2020



CARIBOU STAR

Dimensioni cm

Materiale: polietilene riciclato LDPE. Resistenza ai raggi UV.

Peso: 75 kg.

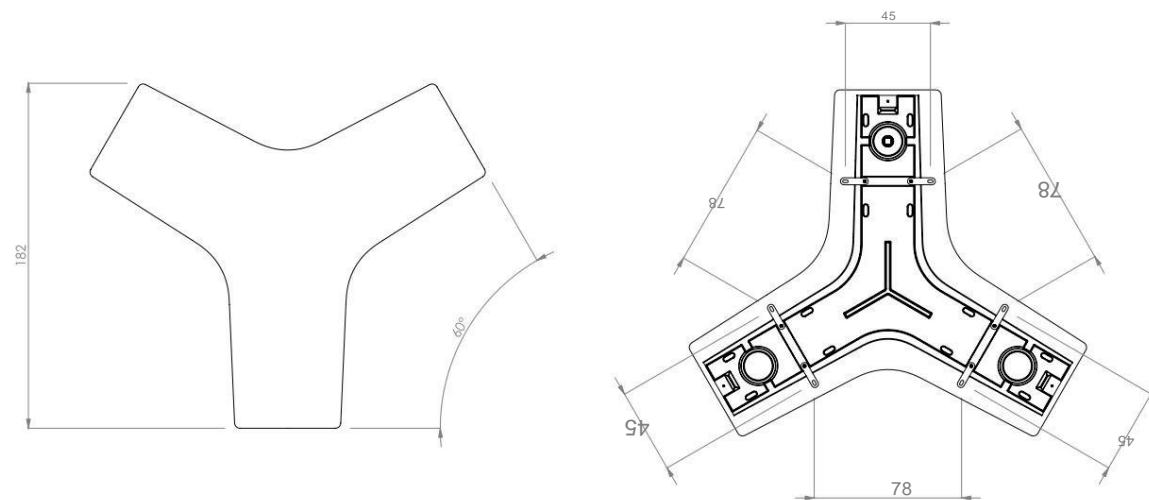
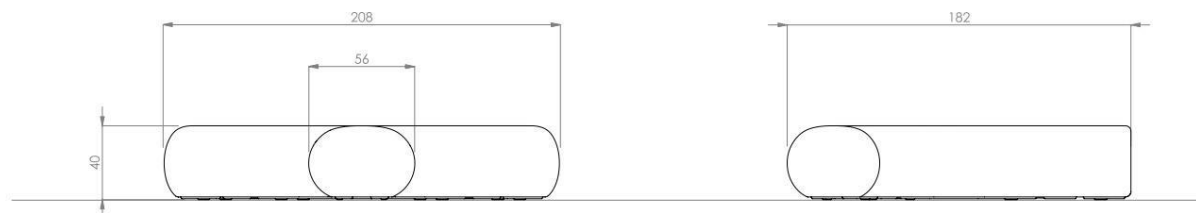
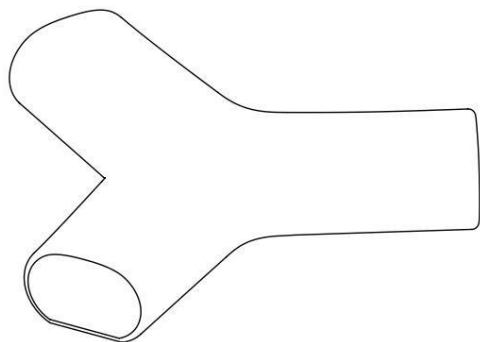

POSIZIONAMENTO DI FISSAGGIO

Sistema di posizionamento

Opzioni di montaggio: Autoportante / Fissaggio diretto forando il pavimento e riempiendo con resina o malta / Riempimento con acqua o sabbia / Fissaggio rimovibile con staffe.

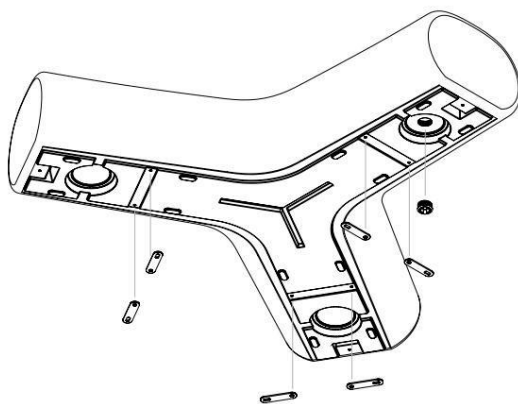

PRINCIPALI CONFIGURAZIONI

